

# Operations Research (OR)

## course04- Modeling2- Multicommodity Flow Problems (MCFP)

Imène AIT ABDERRAHIM  
[i.aitabderrahim@univ-dbkm.dz](mailto:i.aitabderrahim@univ-dbkm.dz)  
Khemis Miliana University

# Outline

- Multicommodity Flow Problem (MCFP)
  - Overview
  - Example (Transshipment problem)
  - Formulation
- Applications and variants of MCFP
- Solution difficulty of MCFP

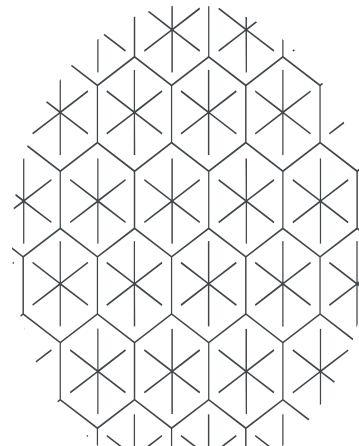

# Multicommodity flows: Overview

## Multiple flows

- in the previous course, we looked at the flow of a single commodity.
- Now let's consider multiple commodities

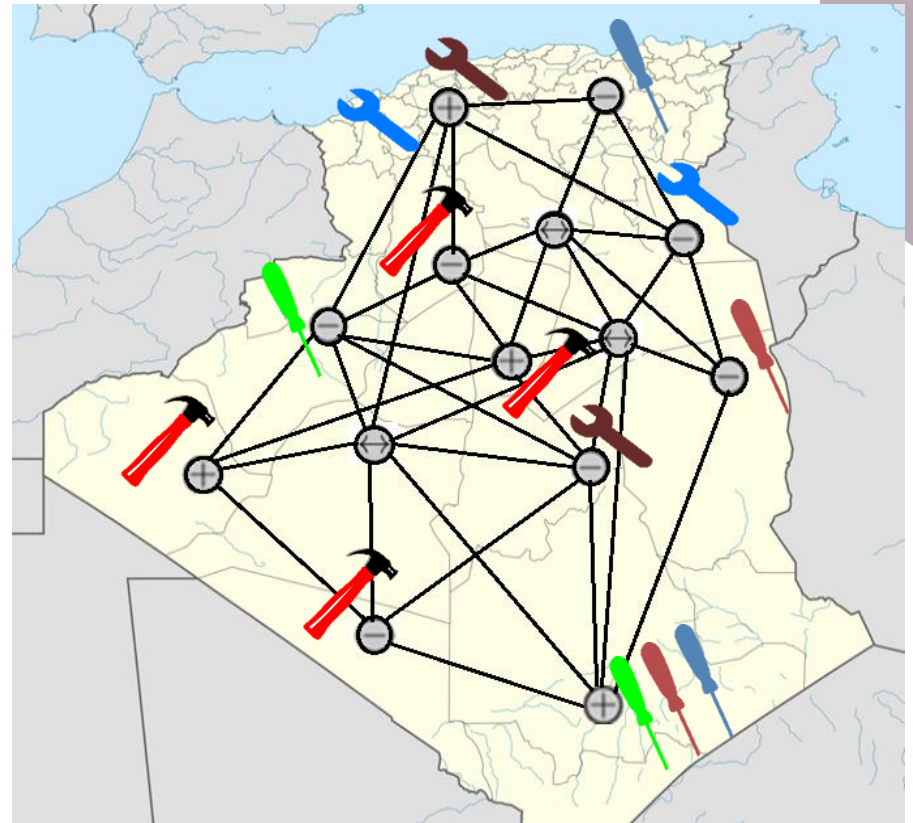

# Multicommodity flows: Assumptions

## Multiple flows

- in the previous course, we looked at the flow of a single commodity.
- Now lets consider multiple commodities

In our example we include the following **assumptions**, we assume that the problem is:

- Single origin/single destination
- Homogeneous commodities
- No congestion
- Fractional flows
- Time not relevant

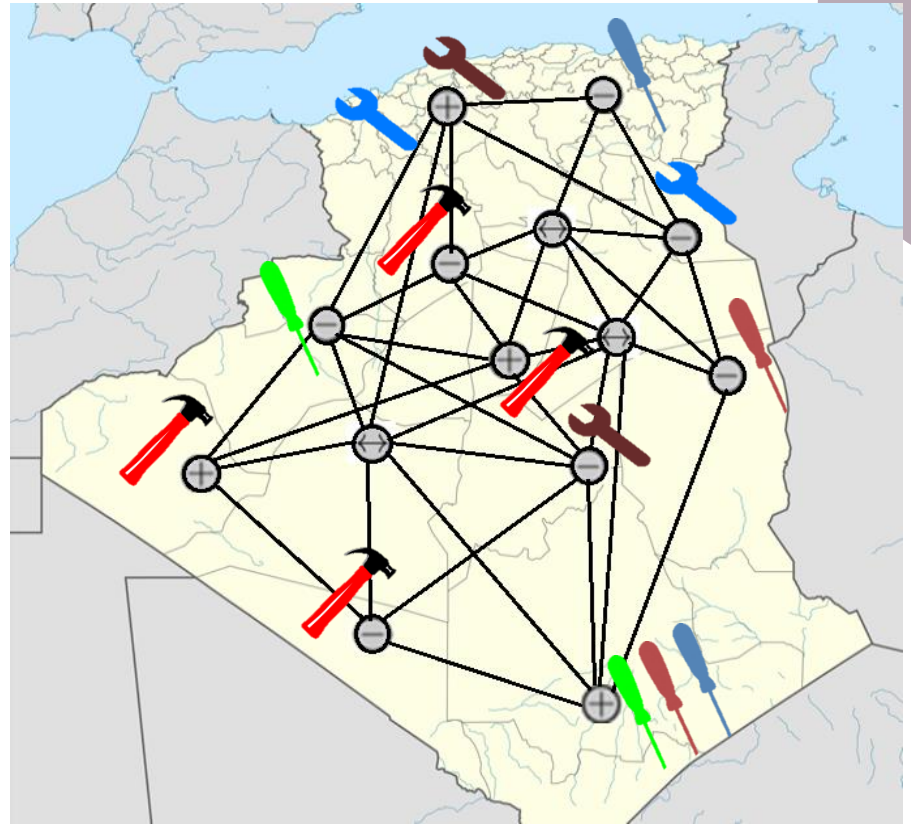

# Multicommodity flows: Example

- This is called MCFP problem because we have multiple flows and different types of products all being considered at the same arcs

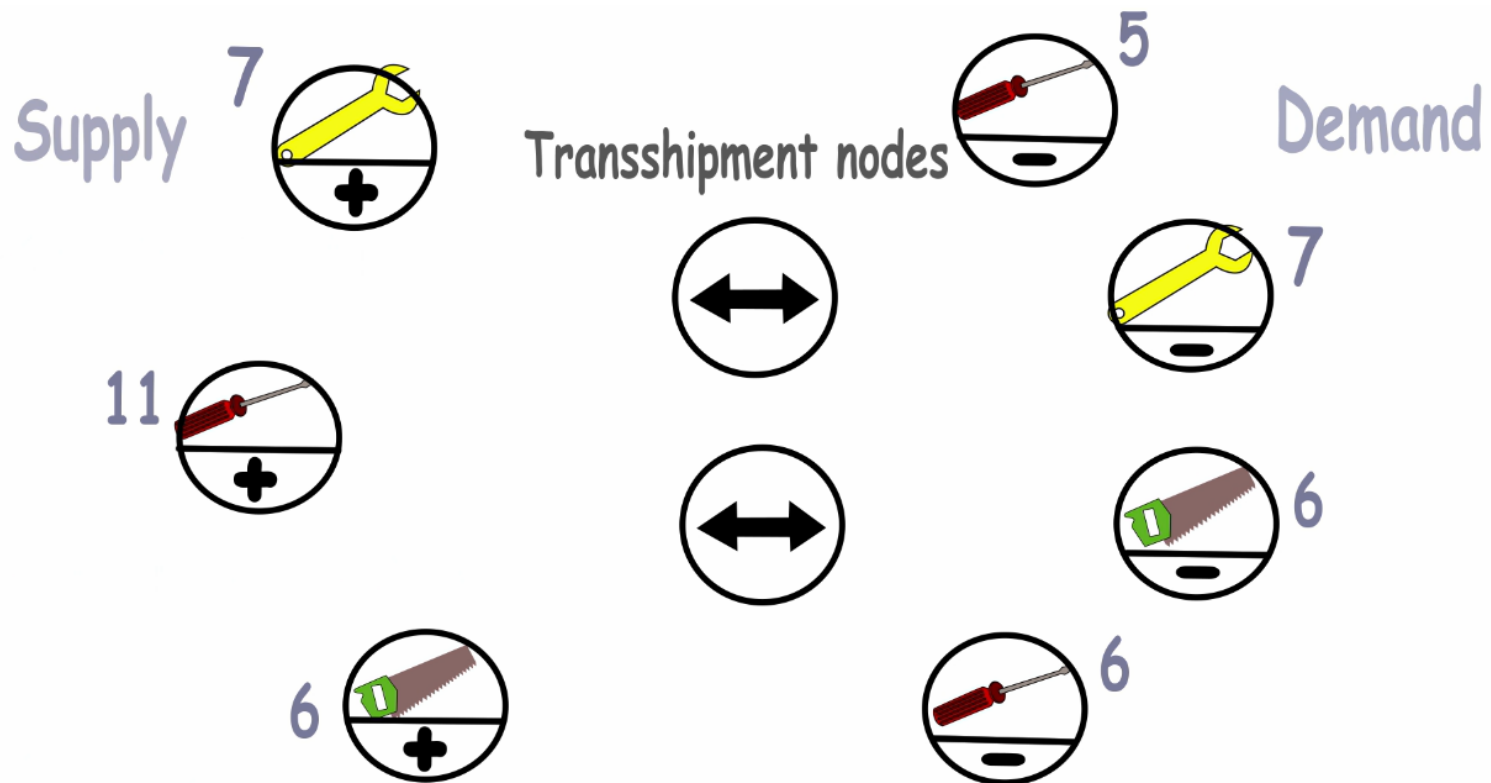

# Multicommodity flows: Example

- Each arc has a cost (just like in the transportation problem),
- In this example, each commodity has an origine and destination.

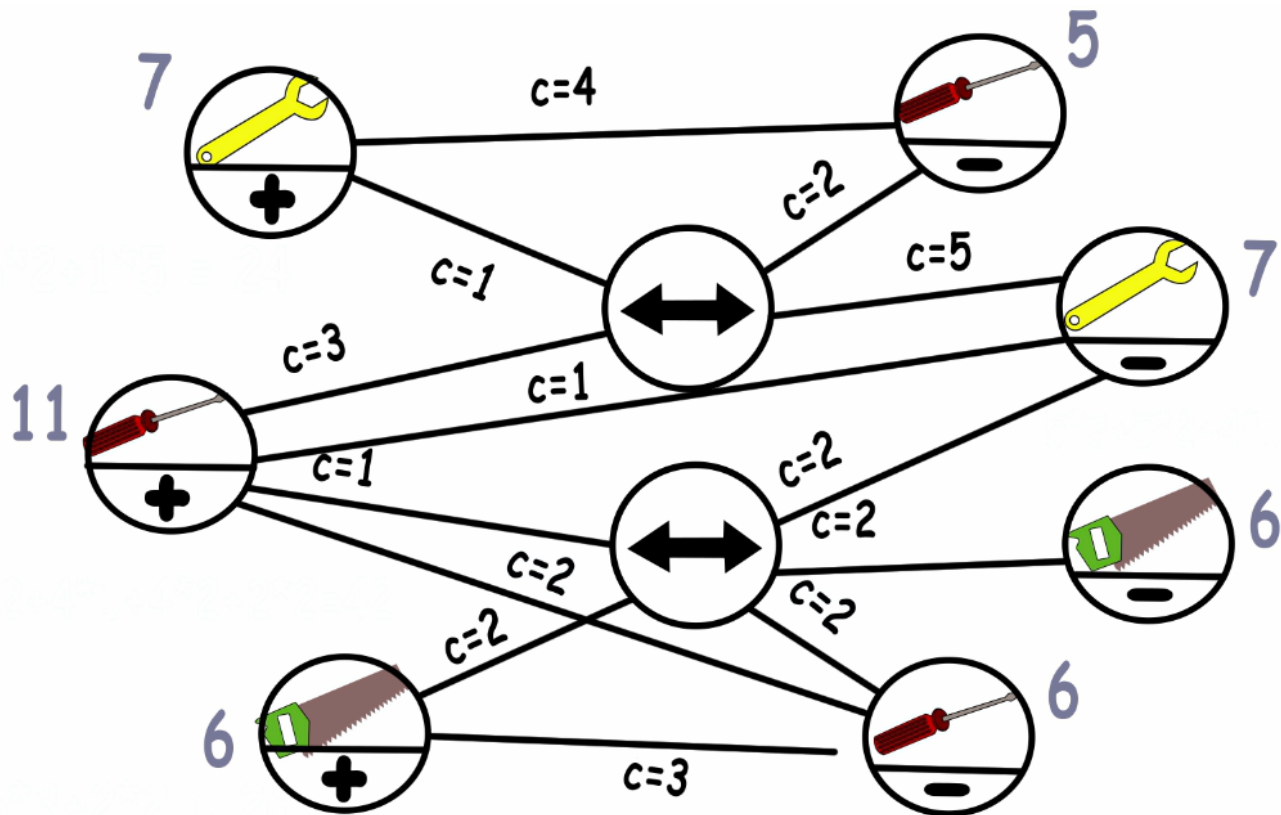

# Multicommodity flows: Example

- Solution1 (potential solution)

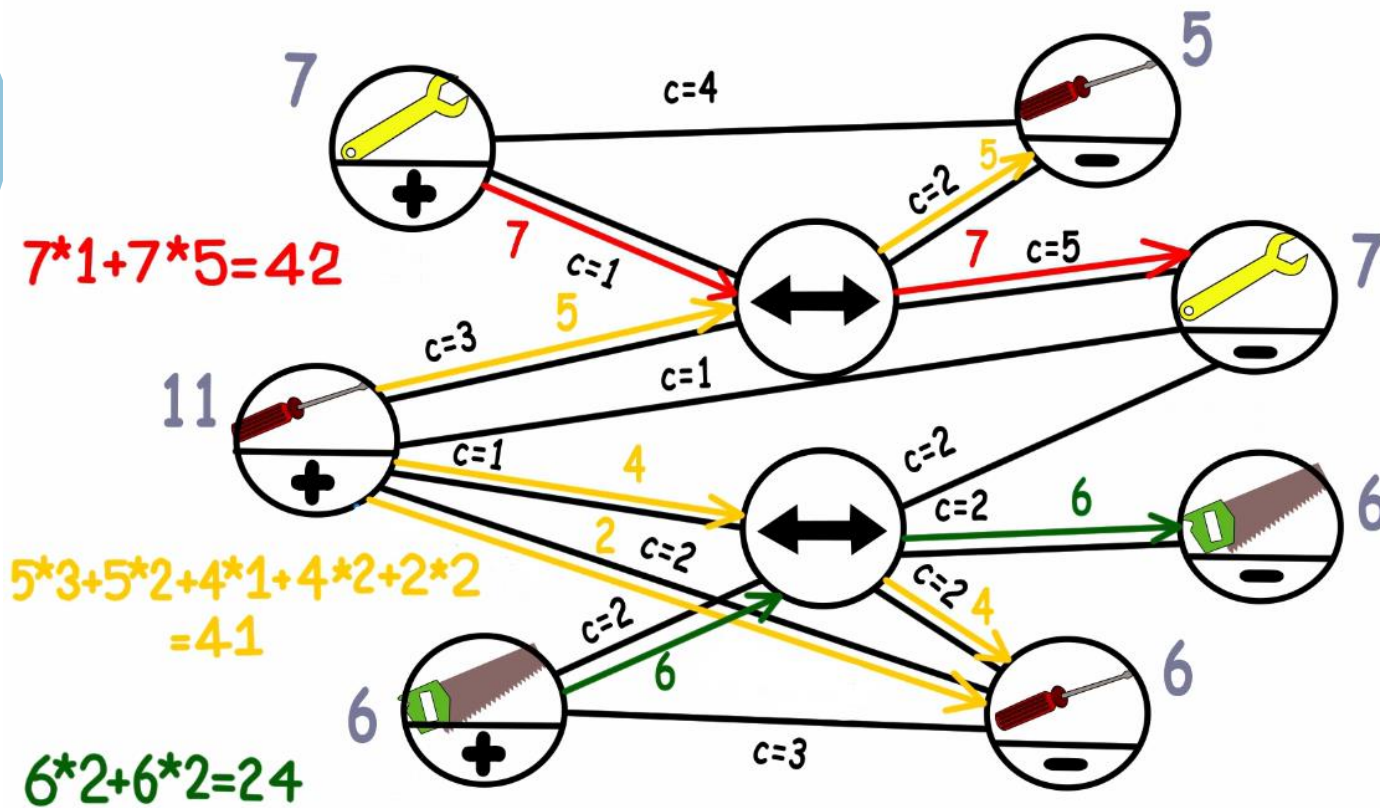

# Multicommodity flows: Example

## Solution 2 (potential solution)

- Let's impose a limited capacity on few arcs (see the blue arrows)

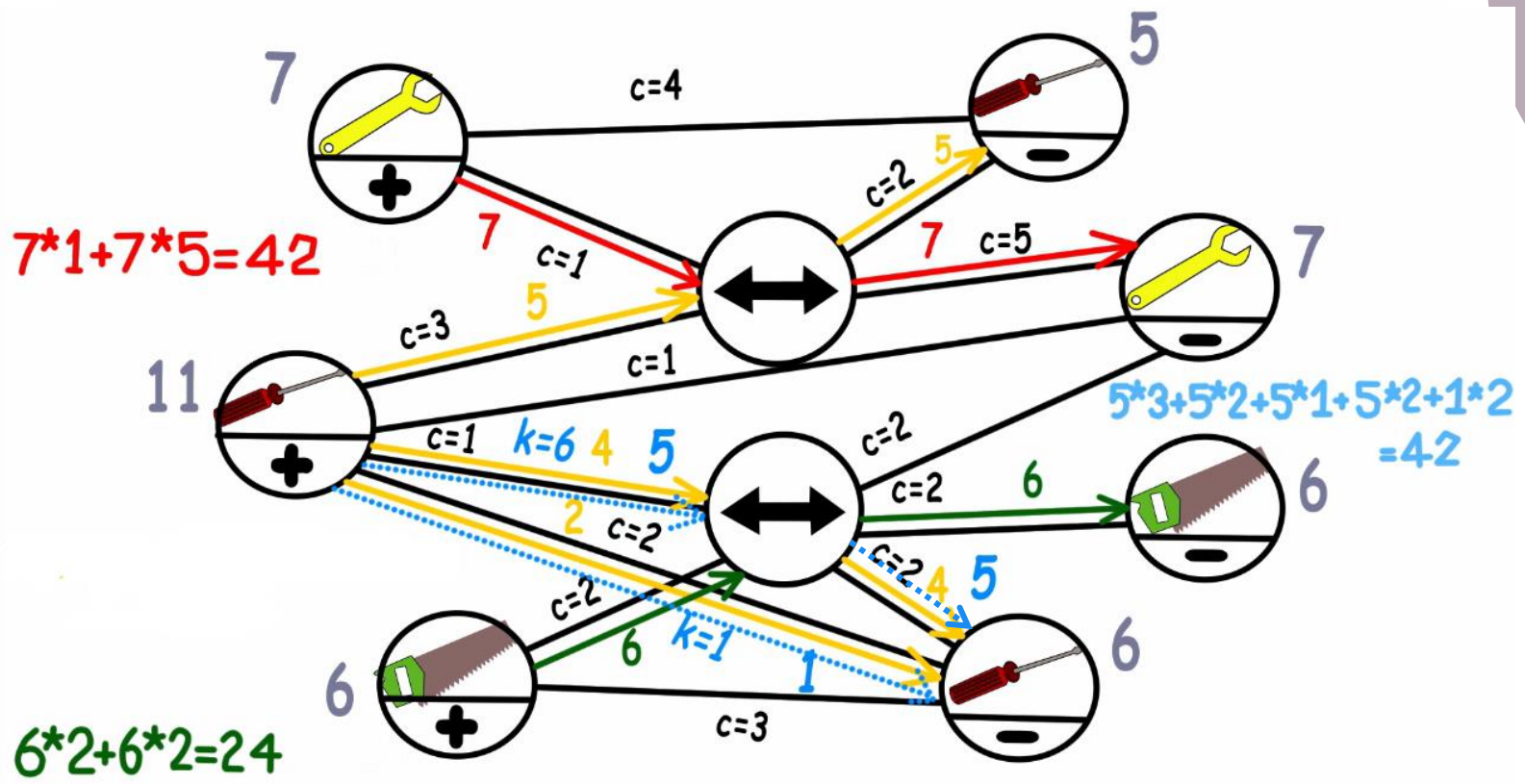



# Multicommodity flows: Example

The total cost for solution2 is a bit more expensive than solution 1.

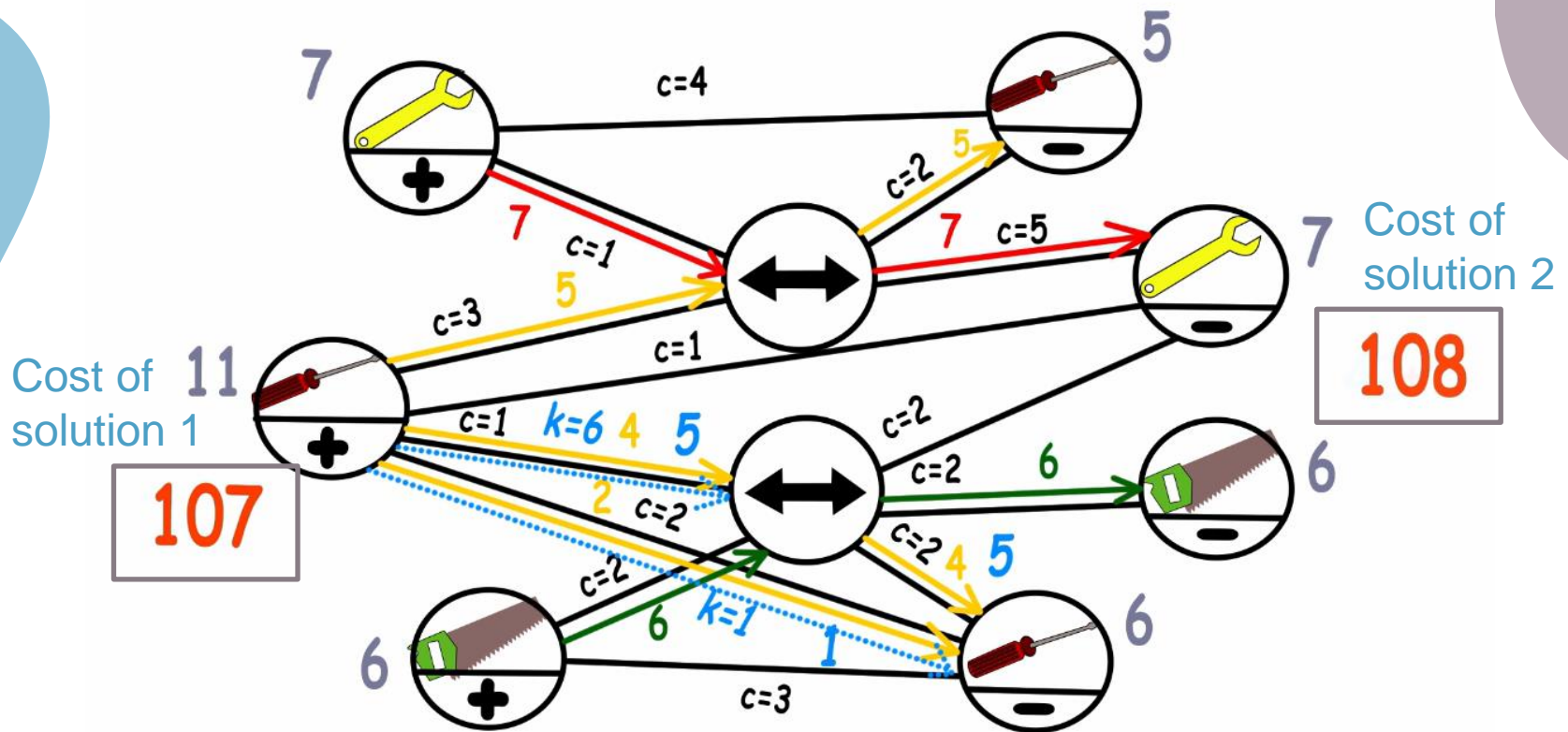



**It is time to model the problem**

# Transshipment problem: Mathematical Formulation

## Parameters and variables

### Parameters:

- Graph  $\mathbf{G} = (N ; A)$ , with  $N = N^+ \cup N^{\leftrightarrow} \cup N^-$
- Supply  $\mathbf{s}_i$  at node  $i \in N^+$
- Demand  $\mathbf{d}_i$  at node  $i \in N^-$
- Cost  $\mathbf{c}_{ij}$  of using arc  $(i, j) \in A$
- Capacity  $\mathbf{\kappa}_{ij}$  of arc  $(i, j) \in A$

### Variables:

- $\mathbf{x}_{ij}$  : Amount of flow on arc  $(i, j) \in A$

# Transshipment problem: Mathematical Formulation

## Objective and constraints

### Parameters:

- Graph  $\mathbf{G} = (N ; A)$
- Supply  $\mathbf{p}_i$
- Demand  $\mathbf{d}_i$
- Cost  $\mathbf{c}_{ij}$
- Capacity  $\mathbf{k}_{ij}$

### Variables:

- Flow  $\mathbf{x}_{ij}$  :

### Objective function:

$$\text{minimize } \sum c_{ij} x_{ij}$$

### Constraints:

$$\text{S.t. } \sum_{(i,j) \in A} x_{ij}$$

$$- \sum_{(j,i) \in A} x_{ji} = \begin{cases} p_i & \text{if } i \in N^+ \\ -d_i & \text{if } i \in N^- \\ 0 & \text{otherwise} \end{cases} \quad \forall i \in N$$

$$0 \leq x_{ij} \leq k_{ij} \quad \forall (i,j) \in A$$

# Applications and variants of MCFP

## Applications:

- Container routing (at sea and on land)  
Containers: Origin, Destination, Amount, Revenue
- Pick-up and delivery problems  
Pick-up locations, amount to pick-up, delivery location
- More applications coming later in the course. . .

## (Some) Variants:

- Unsplittable flow (single path per flow)
- $k$ -splittable flow (up to  $k$  paths per flow)
- Multiple sources/sinks per commodity

# Solution difficulty of MCFP

**Continuous flows:** Polynomial time solvable with an LP

**Integer flows:** NP-Complete, even with only 2 flows! (Evan, Itai and Shamir, 1976)

## **Solving the MCFP:**

- Mixed-integer programming solver (Gurobi, CPLEX, etc.)
- Specialized algorithms (out of scope of this course)
- Approximation techniques

# summary

Today we learned:

- How to model Transshipment flow problem, a MCFP into a linear programming problem (LPP)

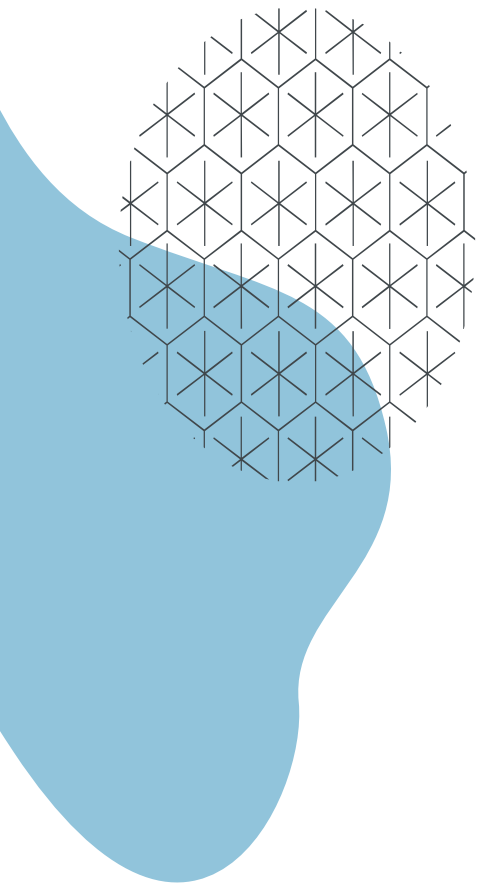

**Questions?**

