

RNN

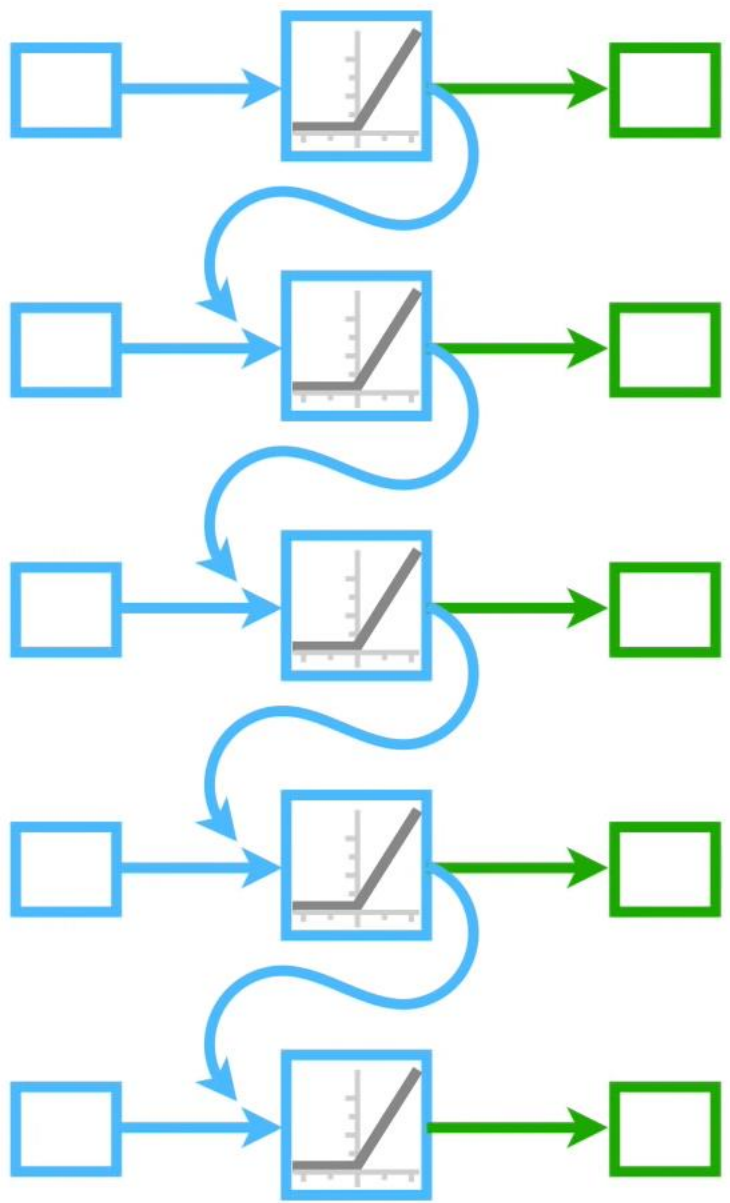

RNN

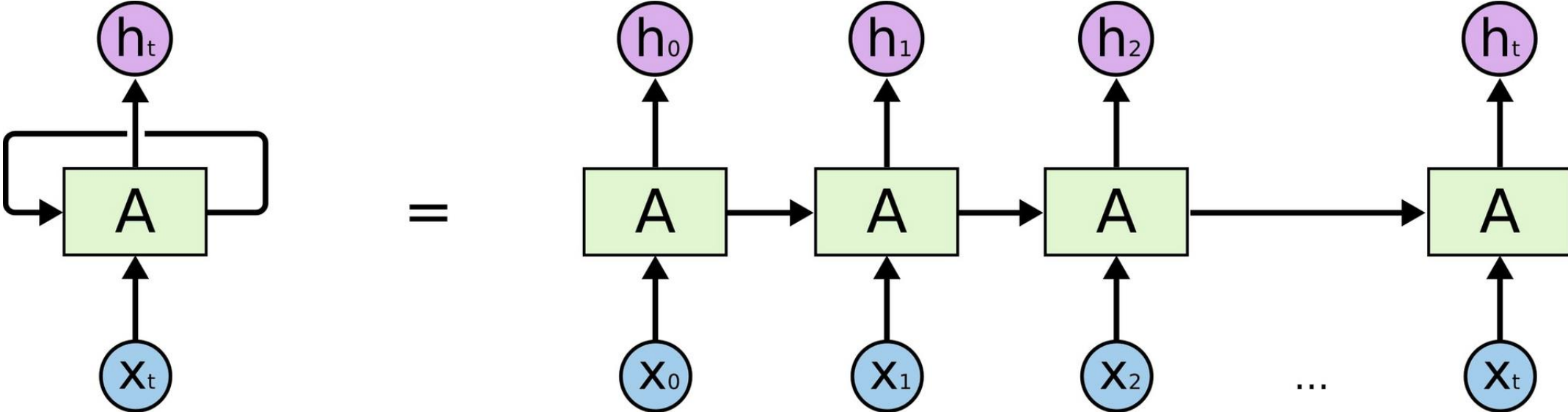

Bidirectional RNN

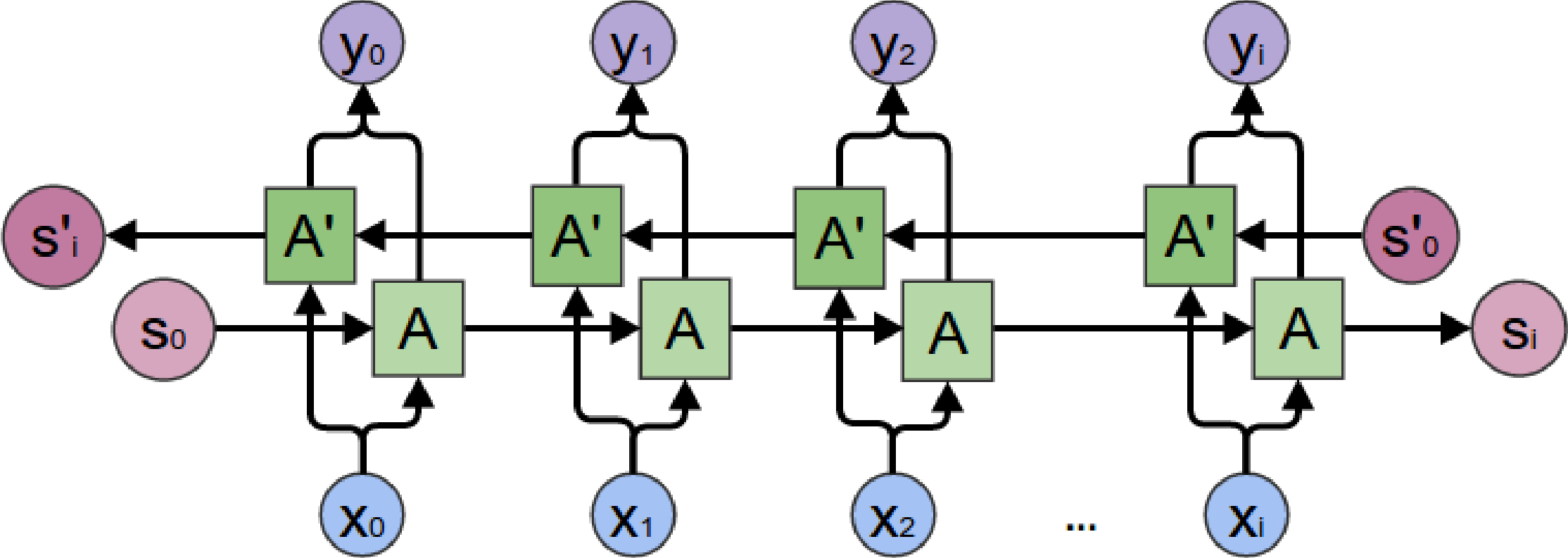



Now that we understand the **main idea** behind **Long Short-Term Memory (LSTM)**, that it uses different paths for **Long** and **Short-Term Memories**...

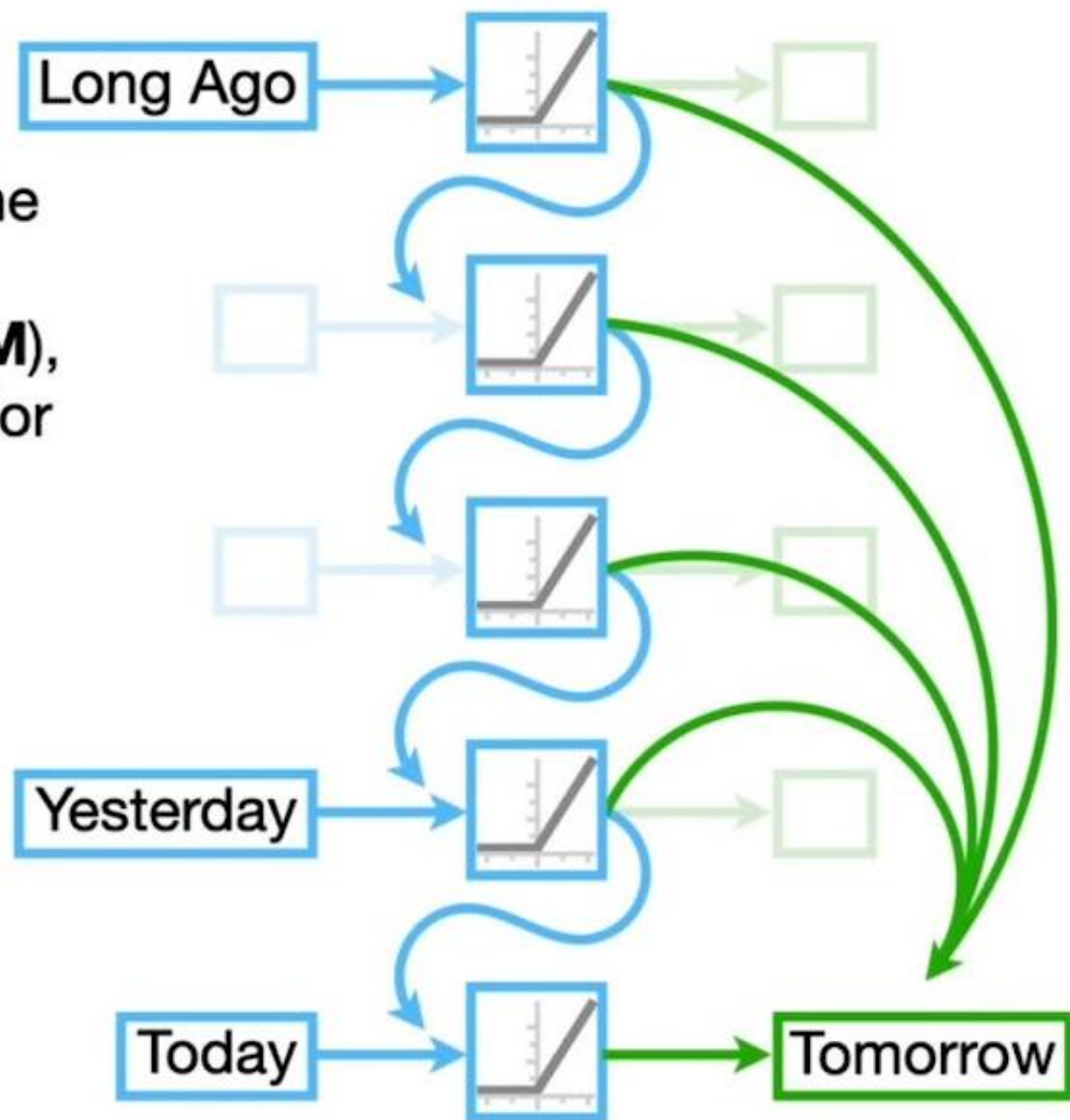



...**Long Short-Term Memory** is based on a much more complicated unit.

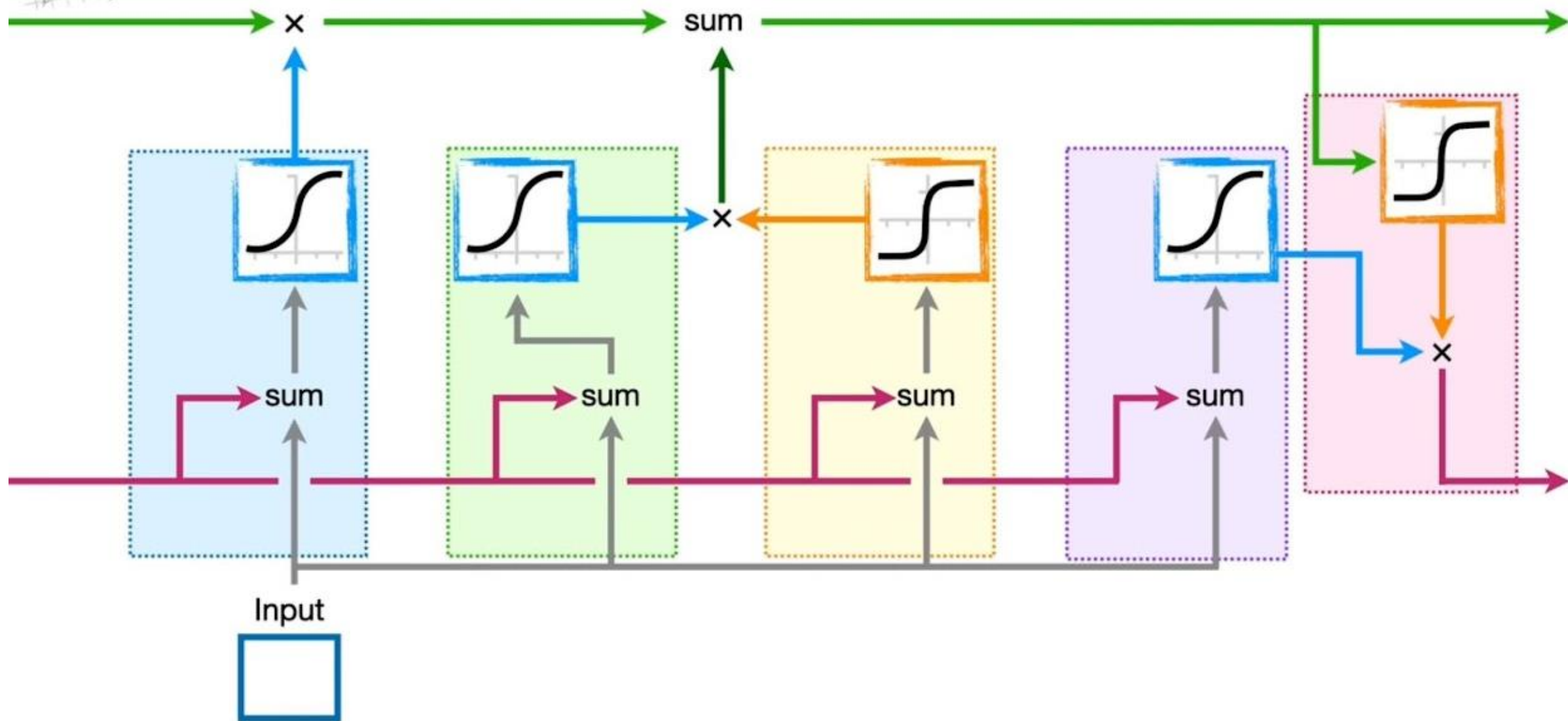

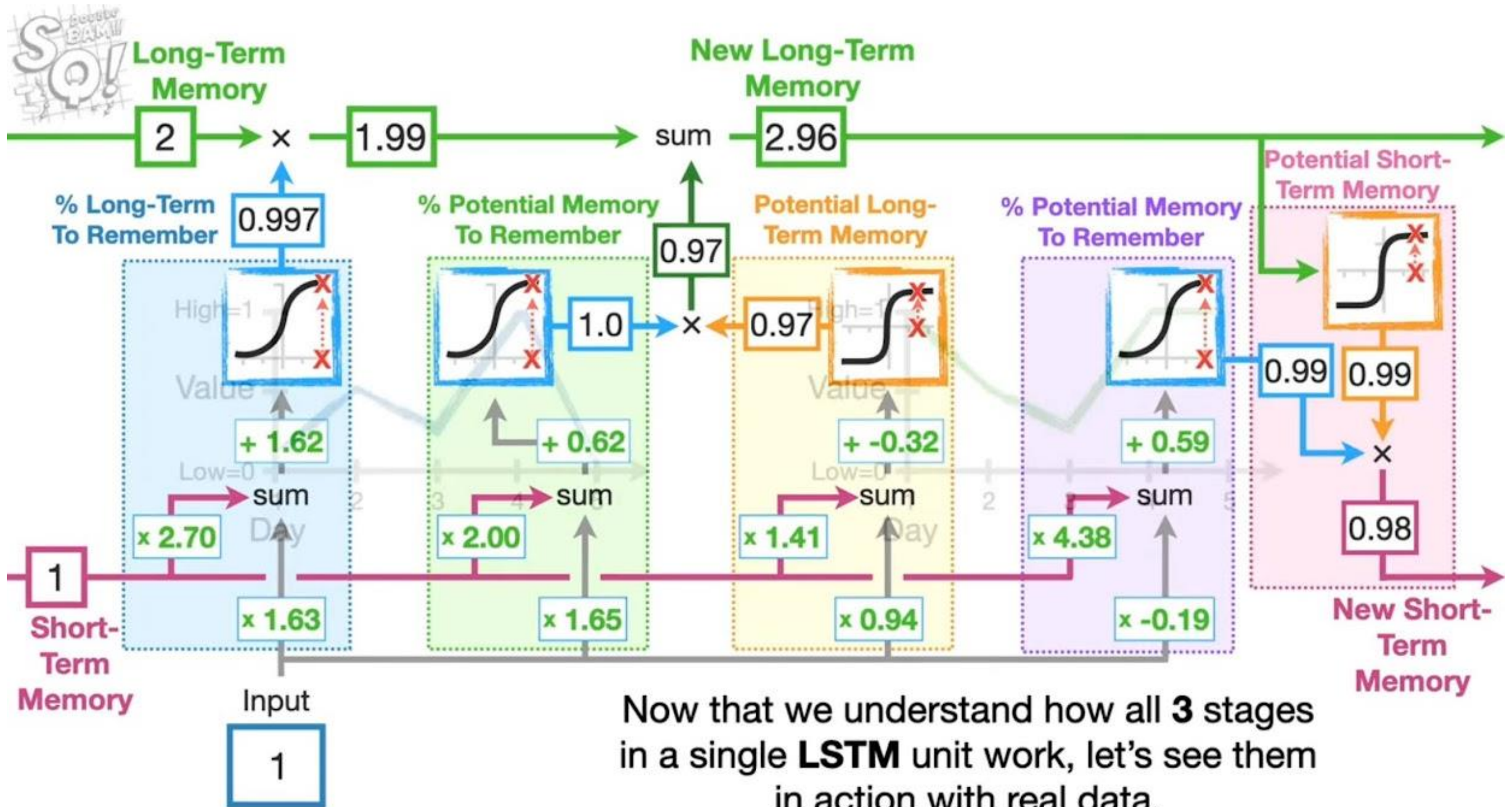

Now that we understand how all **3** stages in a single **LSTM** unit work, let's see them in action with real data.