

Chapter 5

Multi-level inverter

1- Introduction

Inverters are used in applications, including air conditioning, uninterruptible power supply (UPS), high-voltage dc power (HVDC) transmission lines, electric cars, battery storage, and solar panels . Inverters are categorized as square-wave inverters, sinusoidal two-level pulse width modulation (PWM) inverters, and multilevel inverters .

Power electronics, DC-DC converters, and inverters have seen a surge in the study due to the scarcity of fossil fuels and the diversity of renewable energy sources. The converters must be very dependable, efficient, and offer excellent performance due to the high prices of renewable energy supplies . It must generate sinusoidal output waveforms that are synced with the national power grid . Figure 1 shows the circuit diagram of a two-level inverter.

When SW1 is ON, then $V_0 = +(V_{dc}/2)$, and when SW2 is ON, $V_0 = -(V_{dc}/2)$. No need to mention that the conventional two-level inverters without pulse width modulation (PWM) produce a square wave output voltage of two levels, as depicted in Figure 2.

This traditional inverter runs at a high switching frequency for high-power applications, with significant switching losses . Harmonic distortion and excessive stress on power semiconductors are other issues. Because of these issues, connecting power electronic switches to the high-voltage grid is not feasible . These issues necessitate the use of MLI inverters with different topologies. Improved performance at the high switching frequency, reduced harmonic distortion, higher power quality (near to pure sinusoidal), and fewer switching losses are just a few of the benefits of MLI inverters . However, each switch has to have its own gate driver for implementing MLI, which adds to the system's complexity. Therefore, reducing the number of switches of MLI is necessary . This paper presents a review of some of the different current topologies using a lower number of switches.

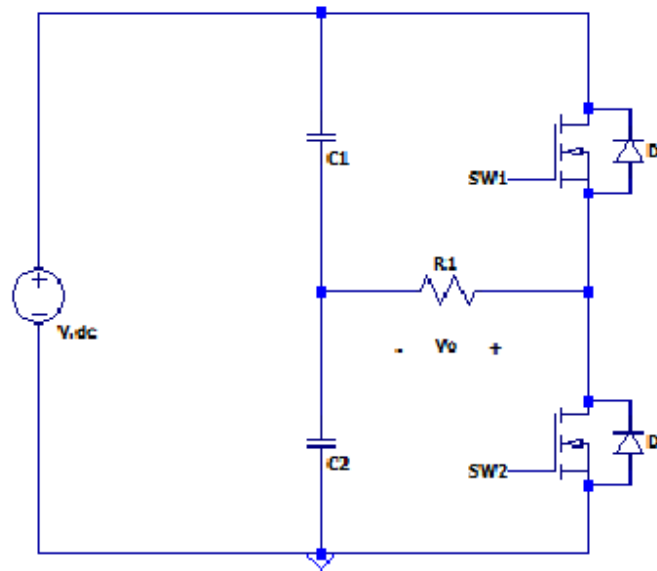

Figure 1. Diagram of a two level inverter

2- Three Types of Classical MLI

From various dc input sources, a multilevel inverter creates a smooth sinusoidal waveform. In addition, multi-level inverters play an important role in high-power industrial applications . Diode-clamped, flying capacitor (capacitor-clamped), and Cascaded H bridge multilevel inverters are the most common topologies . The scheme of multilayer inverters is shown in Figure 3.

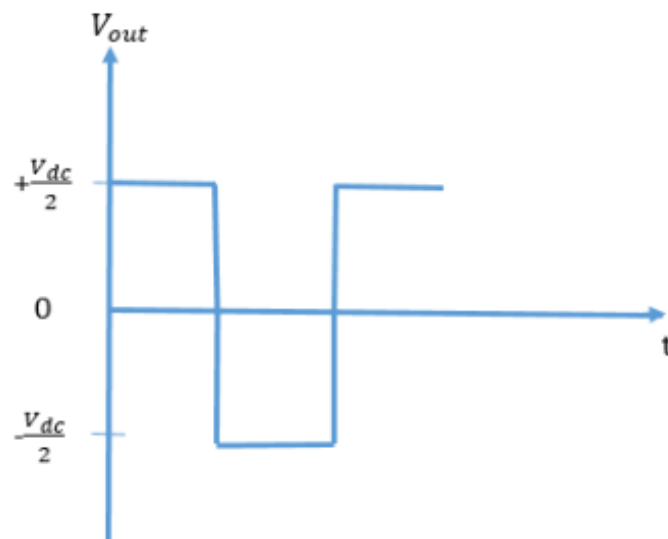

Figure 2. The output voltage of a two-level inverter

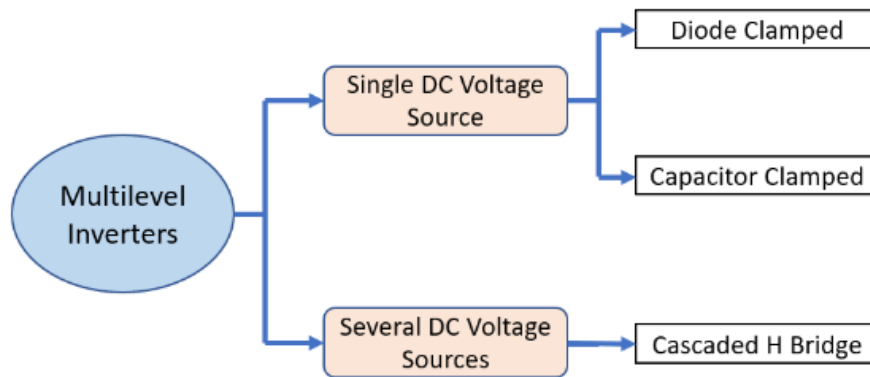

Figure 3. Multilevel inverter scheme

2-1-Diode Clamped Topology

By using diodes, a diode-clamped Multilevel inverter (n level) creates n voltage levels at the output and generally has $(n-1)$ capacitors on the dc-link bus. Figure 4 shows a three-level half-bridge diode clamped multilevel inverter. An n -level inverter requires $(n-1)$ balancing capacitors, $2(n-1)$ switches and $(n-1)(n-2)$ clamping diodes. Therefore, as shown from Figure 4, the three-level classical diode clamped inverter creates three levels of voltage at the output and has two capacitors at the DC bus and four switches, and two clamping diodes.

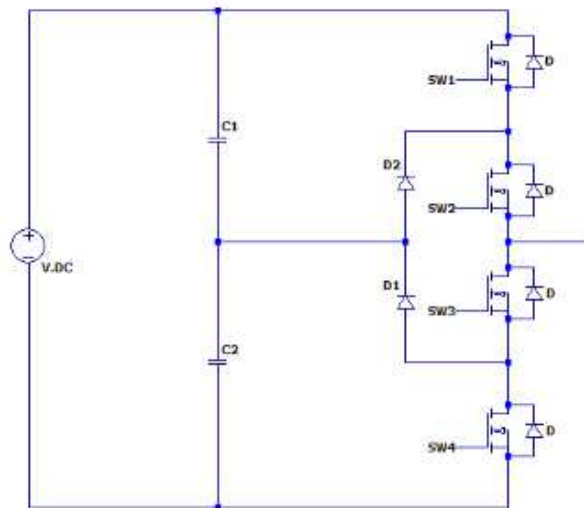

Figure 4. Three-level diode clamped MLI

M1 ELTI

Advanced power Electronics

According to Figure 5, three-level inverters provide a square wave output voltage of three levels without employing PWM.

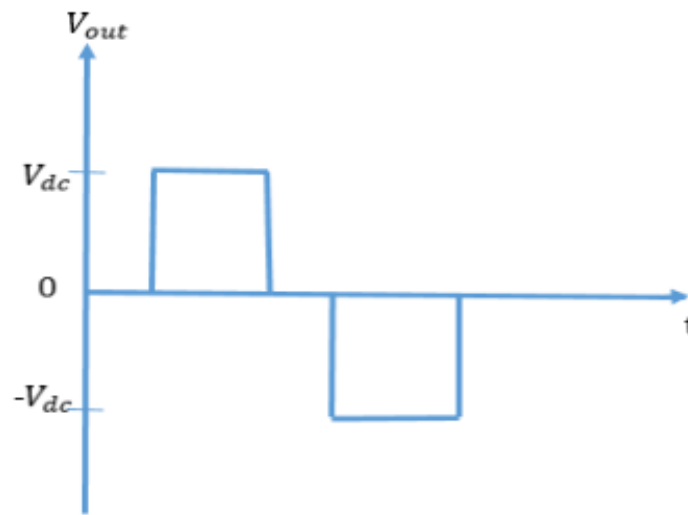

Figure 5. The output waveform of three-level diode clamped MLI

The benefits and drawbacks of diode clamped MLI are as follow

Benefits:

- The real and reactive power flow can be controlled.
- Filters are not required to decrease harmonics.
- The voltage of the switch is just half of the voltage of the dc-link.
- The efficiency is high at the fundamental frequency

Drawbacks:

- Clamping diodes are increased when each level is raised.
- Individual converter real power flow management is challenging.

2-2-Capacitor Clamped Topology

It is different from the diode clamped MLI topology because the capacitors are employed to restrict the voltage in this case. The voltage level of a capacitor's clamped inverter is the same as the diode clamped inverter.

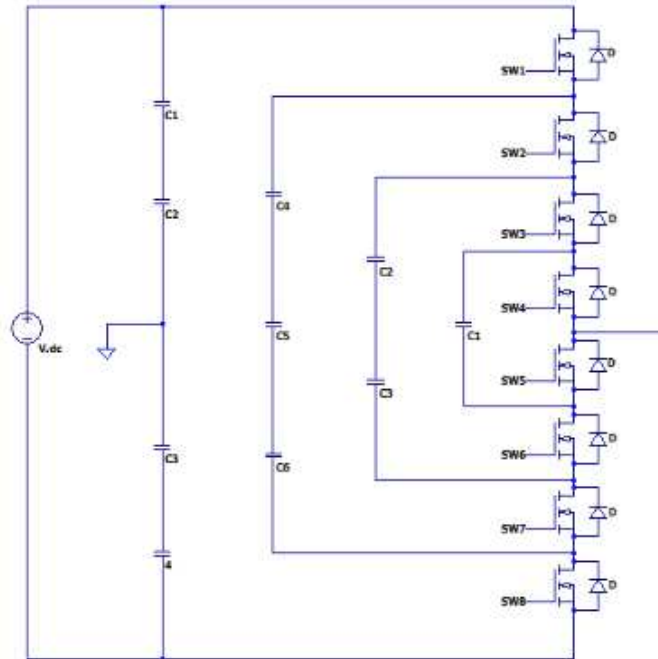

Figure 6. Five-level flying capacitor MLI

For an n-level inverter, the dc bus requires (n-1) capacitors, $(n-1)(n-2)$ 2 number of flying capacitors, and the total number of (n-1) switches is required. For instance, based on Figure 6, a five-level flying capacitor MLI creates five voltage levels at the output and has four capacitors at the DC bus and also has eight switches and six clamping capacitors .

Also, according to Figure 7, the five-level inverters provide a square wave output voltage of five levels without employing PWM.

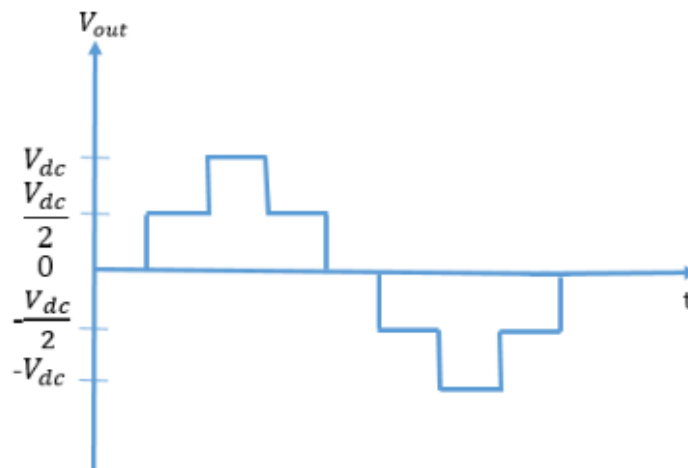

Figure 7. The output waveform of five-level flying capacitor MLI

M1 ELTI

Advanced power Electronics

he benefits and drawbacks of flying capacitor MLI are as follow :

Benefits:

- Get rid of the clamping diode problems.
- Filters are not required to decrease harmonics.
- Reduces the amount of stress on the semiconductor switches.
- It provides the correct switching combination for balancing various voltage levels.
- It is possible to control both real and reactive power flow.

Drawbacks:

- Controlling the voltage across all of the capacitors is hard to achieve.
- A decrease in switching efficiency
- Higher cost because of using more capacitors

2-3-Cascaded H Bridge Topology

A cascaded MLI consists of succession of H-bridge inverters with independent DC sources . In this inverter, the output voltage has a $2s+1$ voltage level, and S is the number of DC inputs. Each cell provides three voltage levels, and the cascaded MLI is made up of connected H-bridge cells in series . Therefore, the output voltage levels are equal to the total voltages generated by each H Bridge cell phone. Figure 8 indicates a seven-level cascaded MLI, which has three separate dc sources.

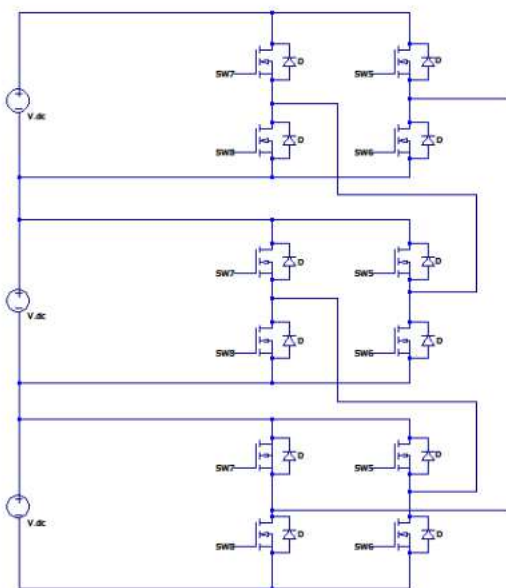

Figure 8. Seven-level H-bridge MLI

M1 ELTI

Advanced power Electronics

Based on Figure 9, the seven-level cascaded inverters provide a square wave output voltage of seven levels without employing PWM.

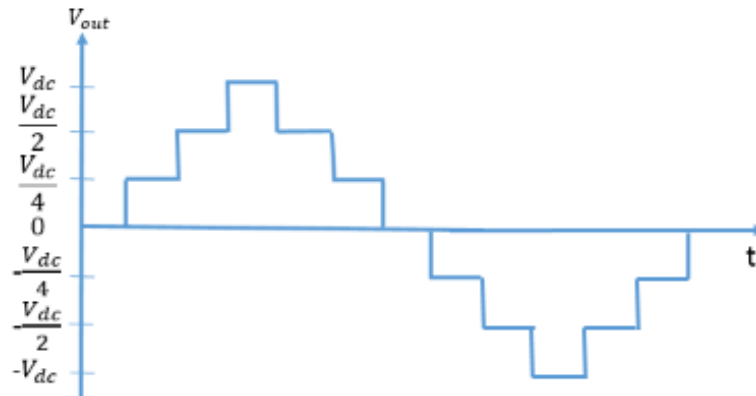

Figure 9. The output waveform of seven-level cascaded MLI

The benefits and drawbacks of cascaded H bridge MLI are as follow [42-44]:

Benefits:

- To decrease switching losses, a soft switching approach can be employed.
- Filters are not required to decrease harmonics.
- THD (total harmonic distortion) is extremely low.
- A lower number of components is used in this MLI.

Drawbacks:

- For power conversions, it requires independent dc sources.