

Chapter 4

DC to DC Converters (Choppers)

Introduction

A dc- to- dc converter, also known as dc chopper, is a static device which is used to obtain a variable dc voltage from a constant dc voltage source. Choppers are widely used in trolley cars, battery operated vehicles, traction motor control, control of large number of dc motors, etc. They are also used as dc voltage regulators.

Choppers are of two types: (1) Step- down choppers, and (2) Step- up choppers. In step- down choppers, the output voltage will be less than the input voltage, whereas in step- up choppers output voltage will be more than the input voltage.

4.1 principle of step-down chopper

Figure 4.1 shows a step-down chopper with resistive load. When the switch is ON, supply voltage appears across the load and when switch is OFF, the voltage across the load will be zero. The output voltage waveform is as shown in Fig.4.1.

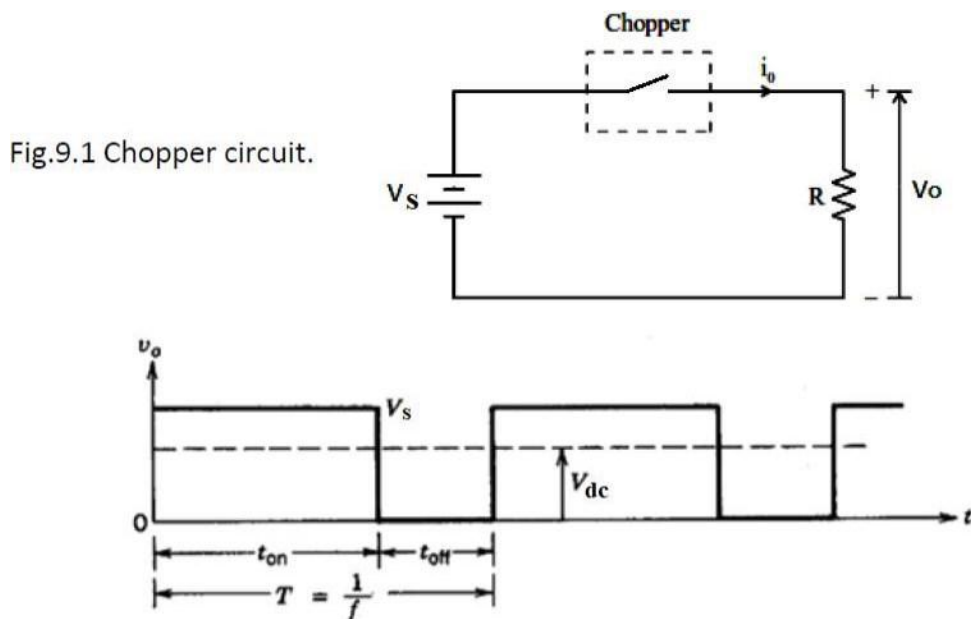

Fig.9.2 Chopper output voltage waveform, R- load.

Methods of Control

The output dc voltage can be varied by the following methods.

- ❖ Constant frequency control.
- ❖ Variable frequency control.

Constant frequency control.

- t_{ON} is varied keeping chopping frequency ' f ' & chopping period ' T ' constant.
- Output voltage is varied by varying the ON time t_{ON}

Referring to Fig.9.2, the average output voltage v_{dc} can be found as

Let $T = \text{control period} = t_{on} + t_{off}$

$$V_{dc} = V_{av} = \frac{1}{T} \int_0^{t_{on}} V_s dt$$

$$V_{dc} = V_s \frac{t_{on}}{T} = V_s D$$

where, $D = \frac{t_{on}}{T} = \text{Duty cycle}$

- Maximum value of $D = 1$ when $t_{on} = T$ ($t_{off} = 0$)
- Minimum value of $D = 0$ when $t_{on} = 0$ ($t_{off} = T$)

The output voltage is stepped down by the factor D ($0 \leq V_{dc} \leq V_s$). Therefore this form of chopper is a step down chopper.

The average value of the output current in case of resistive load:

$$I_{dc} = \frac{V_{dc}}{R} = \frac{DV_s}{R}$$

The R.M.S. value of the output voltage

$$V_{rms} = \sqrt{\frac{1}{T} \int_0^T (V_s)^2 dt} = V_s \sqrt{\frac{D}{T}} = V_s \sqrt{D}$$

$$I_{rms} = \frac{V_{rms}}{R} = \frac{V_s \sqrt{D}}{R}$$

$$f = \text{chopping frequency} = \left(\frac{1}{\text{chopping period}(T)} \right) = 1/T$$

The ripple factor, RF

It is a measure of the ripple content.

$$R_F = \sqrt{\left(\frac{V_{rms}}{V_{DC}} \right)^2 - 1} = \sqrt{\frac{V_s^2 D}{V_s^2 D^2} - 1} = \sqrt{\frac{1-D}{D}}$$

Example 1: A transistor dc chopper circuit (Buck converter) is supplied with power from an ideal battery of 100 V. The load voltage waveform consists of rectangular pulses of duration 1 ms in an overall cycle time of 2.5 ms. Calculate, for resistive load of 10 Ω .

- The duty cycle .
- The average value of the output voltage .
- The ripple factor RF .
- The output d.c. power.

(a) $t_{on} = 1\text{ms}$, $T=2.5\text{ ms}$

$$D = \frac{t_{on}}{T} = \frac{1\text{ ms}}{2.5\text{ ms}} = 0.4$$

(b) $V_{dc} = DV_s = 0.4 \times 100 = 40\text{ V}$.

(c) $RF = \sqrt{\frac{1-D}{D}} = \sqrt{\frac{1-0.4}{0.4}} = 1.225$

(d) $I_{dc} = \frac{V_{dc}}{R} = \frac{40}{10} = 4\text{A}$

$$P_{dc} = I_{dc} V_{dc} = 4 \times 40 = 160\text{ W}$$

4.2 Step-up Chopper (Boost converter)

The boost converter is shown in Figure below. This is another switching converter that operates by periodically opening and closing an electronic switch. It is called a boost converter because the output voltage is larger than the input.

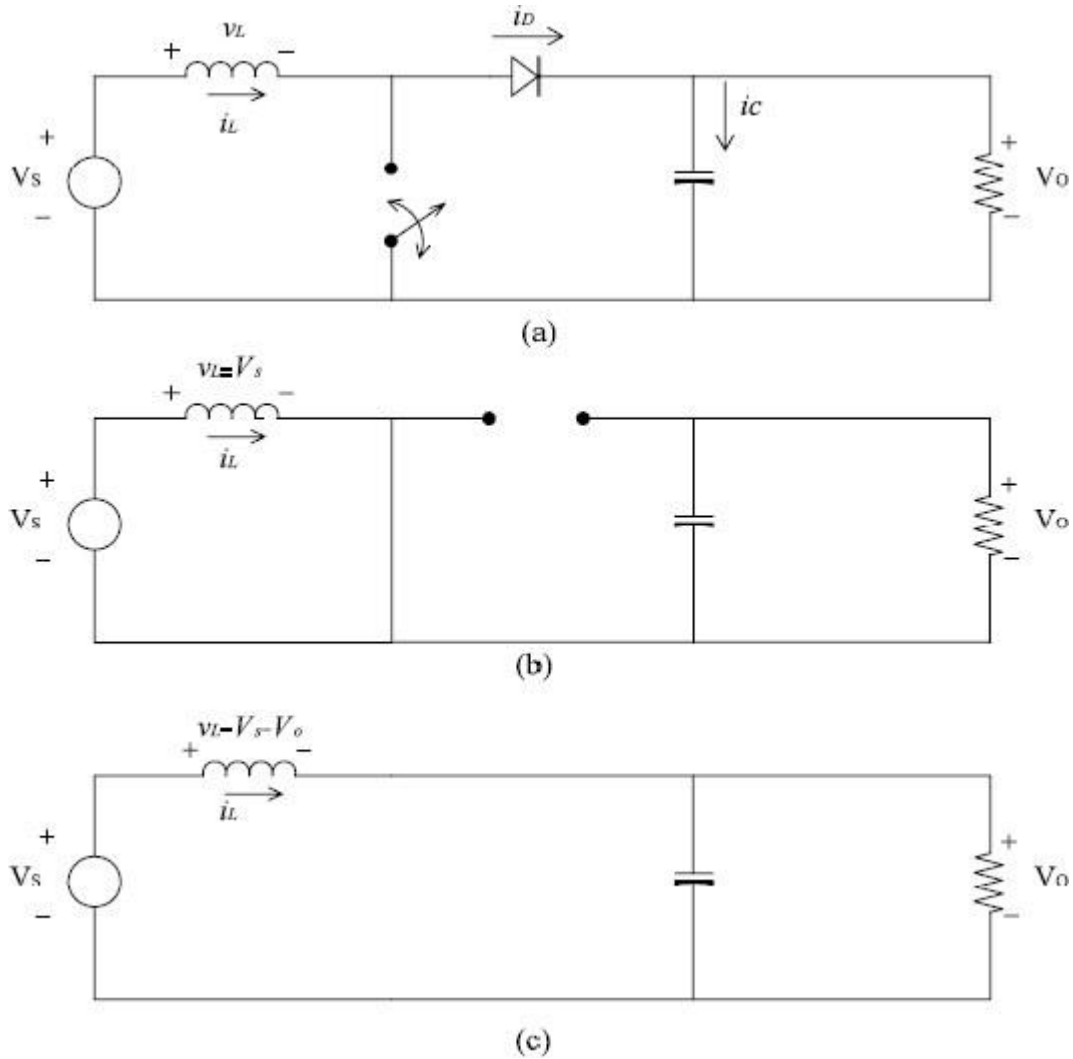

Figure: The boost converter: (a) Circuit. (b) Equivalent for the switch closed. (c) Equivalent for the switch open.

If the switch is always open and D is zero, the output voltage is the same as the input. As the duty ratio is increased, the denominator of equation above becomes smaller, resulting in a larger output voltage. The boost converter produces an output voltage that is greater than or equal to the input voltage. However, the

output voltage cannot be less than the input.

The average current in the inductor is determined by recognizing that the average power supplied by the source must be the same as the average power absorbed by the load resistor. Output power is

$$P_o = \frac{V_o^2}{R} = V_o I_o$$

Input power is $V_s I_s = V_s I_L$.

$$V_s I_L = \frac{V_o^2}{R} = \frac{[V_s/(1-D)]^2}{R} = \frac{V_s^2}{(1-D)^2 R}$$

$$I_L = \frac{V_s}{(1-D)^2 R}$$

Maximum and minimum inductor currents are determined by using the average value and the change in current

$$I_{\max} = I_L + \frac{\Delta i_L}{2} = \frac{V_s}{(1-D)^2 R} + \frac{V_s D T}{2L}$$

$$I_{\min} = I_L - \frac{\Delta i_L}{2} = \frac{V_s}{(1-D)^2 R} - \frac{V_s D T}{2L}$$

$$L_{\min} = \frac{D(1-D)^2 R}{2f}$$

$$C = \frac{D}{R(\Delta V_o/V_o)f}$$

Example: Design a boost converter that will have an output of 30 V from a 12 V source. Design for continuous inductor current and an output ripple voltage of less

than 1%. The load is a resistance of 50Ω and the switching frequency is 25kHz. Assume ideal components for this design.

Solution:

$$V_{DC} = \frac{V_S}{1 - D}$$

$$D = 1 - \frac{V_S}{V_{DC}}$$

$$D = 1 - \frac{12}{30} = 0.6$$

$$L_{min} = \frac{(1 - D)^2 R}{2f} = \frac{0.6(1 - 0.6)^2 * 50}{2 * 25000}$$

Let $L = 120 \mu H$ to ensure the inductor current is continuous.

$$I_L = \frac{V_S}{(1 - D)^2 R}$$

$$I_L = \frac{12}{(1 - 0.6)^2 * 50} = 1.5A$$

$$\Delta i = \frac{V_S D}{LF} = \frac{12 * 0.6}{(120 * 10^{-6})(25 * 10^3)} = 2.4A$$

$$I_{max} = 1.5 + 1.2 = 2.7A$$

$$I_{min} = 1.5 - 1.2 = 0.3A$$

$$C_{min} = \frac{D}{R \left(\frac{\Delta V_o}{V_o}\right) F_s} = \frac{0.6}{50(0.01)(25 * 10^3)} = 48\mu F$$