

Series 3

Design methods of static converters at systematic switching

Exercise 1

According to the following scheme, answer to these questions:

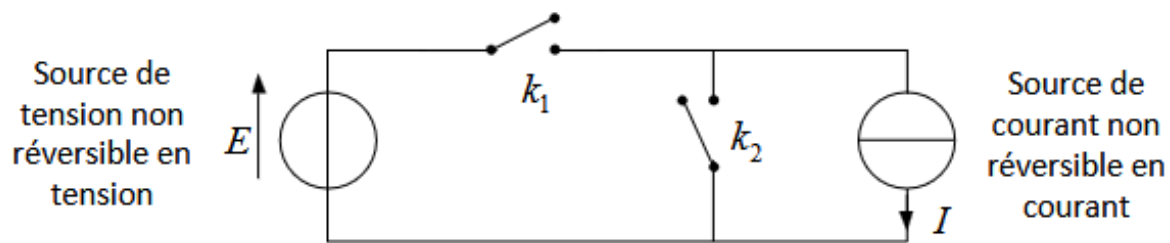

- 1- On the table mention the functional sequences between k_1 and k_2 .
- 2- Draw the circuit under different possible configurations.
- 3- Illustrate the static characteristics of the switches.
- 4- The same question 3 , but with dynamic characteristics.
- 5- Identify the switches.
- 6- Structured the studied converter.

Exercise 2 :

Figure (1) shows a DC-DC converter allowing the transfer of energy between two sources. One is bidirectional in voltage and unidirectional in current and the other is a unidirectional in voltage and bidirectional in current source. The control of the converter is shown in figure (2).

- 1) - Give the nature of each source (voltage or current). - In order to specify the reversibility of each source, fill in the following table by checking the correct box.

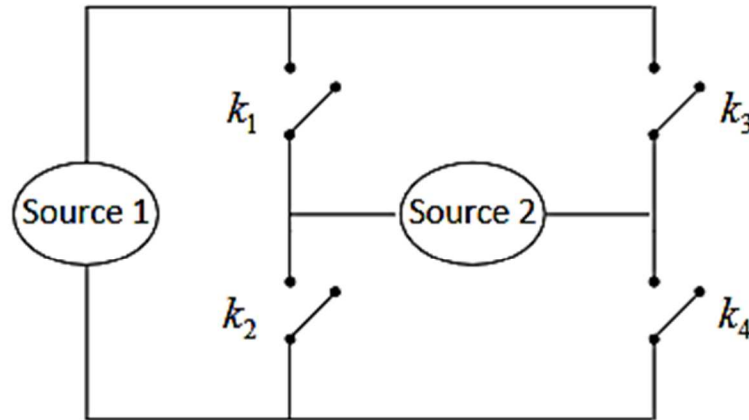

Figure (1)

	Source 1	Source 2
Unidirectionnelle en courant		
Bidirectionnelle en courant		
Unidirectionnelle en tension		
Bidirectionnelle en tension		

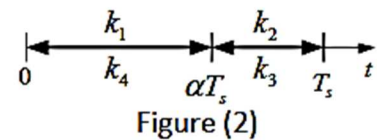

Figure (2)

- 2) Trace the circuits of the possible configurations.
- 3) Trace the static characteristics of the switches.
- 4) Complete the table below by giving the type of switching of each switch (spontaneous or controlled).

	Amorçage	Blocage
k_1		
k_2		
k_3		
k_4		

- 5) Plotting the dynamic characteristics of switches
- 6) Propose a diagram of the converter by replacing the switches with suitable semiconductors.
- 7) If we assume that the currents flowing through the two switches 1k and 2k and the voltages at their terminals, during switching on and off, are shown in figure (3).

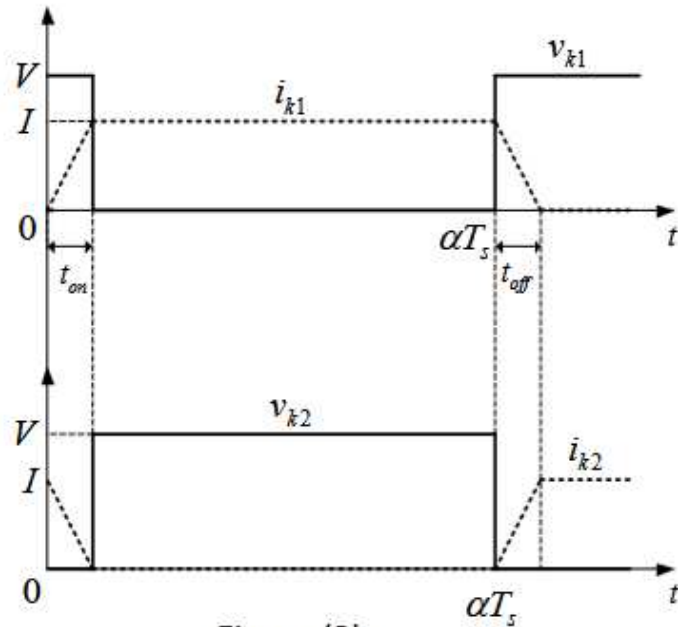

Figure (3)

8) Calculate the power lost by switching in the two switches then deduce that dissipated in the converter knowing that: $V= 200V$, $I=10 A$, $T=20 \mu s$, $t_{on}=0.5 \mu s$ and $t_{off}=0.4 \mu s$.